

**Ambani**  
METALS

RELIABLE FOUNDATION, REMARKABLE FUTURES!

**MASS TRANSFER SOLUTIONS**

TRAYS | PACKING | INTERNALS



## Table of Content

In the realm of process design, engineering, and manufacturing, the pivotal role of mass transfer processes cannot be overstated. Specifically, within the domains of distillation, absorption, and extraction technologies, the efficiency and success of these processes rely heavily on the intricate understanding and application of mass transfer principles.

### Distillation Trays

- Bubble Cap Tray [AMB Tray 1]
- Sieve Tray [AMB TRAY 2]
- Floating Valve Tray [AMB TRAY 3]
- Fixed Valve Tray [AMB TRAY 4]

### Structured Packing

- AMBSTRUC Series Structured Packing
- High Capacity Vantage Structured Packing [AMBSTRUC Plus]
- Wire Mesh Structured Packing [AMB MESH]
- Lab Structured Packing [AMB-LAB]

### Random Packing

- Pall Ring [AMB - PALL]
- Raschig Ring [AMB - RR]
- Saddle Ring [AMB - SR]
- Cascade Mini Ring [AMB - CMR]

We also manufacture various other rings like - Super Raschig Ring, Cannon Ring, Dixon Ring, etc. (For more information view our [Random Packing page/catalogue](#))

### Column Internals

- Liquid Distributor & Redistributors [AMB - D/AMB - RD]
- Chimney Tray Collector - Distributor [AMB - CCR]
- Feed Pipe Distributor [AMB - FPD]
- L- L Extraction Distributor [AMB - ED]
- Spray Nozzle Type Distributor [AMB - SND]
- Through Type Distributor [AMB - TTD]
- Vane Type Collectors [AMB - VC]
- Flanged Type Collectors [AMB - FC]
- Chimney Tray Type Collectors [AMB - CC]
- Collectors With Support Grid [AMB - SGC]
- Demister Pads [AMB - DEM]



#### Head Office

Office no. 2, 2<sup>nd</sup> floor, Nebula Tower, Sindhi Lane, Mumbai - 40004, Maharashtra, India.



#### Contact Person

Jay Shah - Domestic Division - +91 83692000178  
Manan Bokadia - Export Division - +91 9930498865



#### Email

sales@ambanimetal.com  
export@ambanimetal.com



#### Website

<http://www.ambanimetal.com>



## Distillation Trays

Ambani Metals presents a selection of Distillation Trays designed for diverse separation purposes, accommodating different column dimensions. These trays are easily deployable and require minimal regular maintenance. Crafted from various metallic materials using punching and bending processes, we manufacture trays tailored for applications in industries such as hydrocarbon processing, chemical, desalination, petrochemical, and gas-liquid absorption units. Our specialized Column Internals encompass Floating Valve Tray, Bubble Cap Tray, Fixed Valve Tray, Grid tray, and Sieve Tray, catering to the varied needs of different sectors.

Collaborating with our skilled process engineers, we assist you in choosing the most suitable trays for your specific requirements. Furthermore, our proficient team is ready for prompt installation upon your request. Irrespective of the application, Ambani Metals offers random packing in diverse sizes and materials for distillation trays to ensure optimal performance. We provide a comprehensive array of tray sizes in common materials, all available for shipping at competitive prices.

### Bubble Cap Tray [AMB TRAY 1]

Bubble Cap Trays stand as the initial type of trays utilized in distillation procedures. Termed as "liquid sealed" trays, these trays incorporate vapor ascending through brief pipes called risers, each capped with a serrated edge or slots. Irrespective of the vapor flow rates, these trays sustain a steady liquid level, providing the benefit of accommodating a wide range of liquid flow rates.

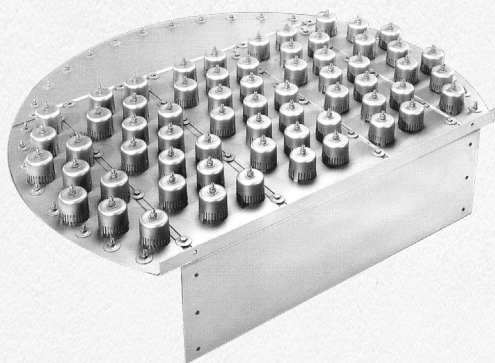

Material of Construction

SS 304/L, SS 316/L, 904L, 254SMO, Duplex, Super Duplex, Titanium, Hastelloy, Monel, Inconel, Copper or any metal/alloy as per customer request

Key Characteristics

Bubble Cap Tray used for low liquid loads. Very wide turndown ratio

Available Size

Bubble Cap Trays are available up to upto 6m with 50 - 100 mm caps

### Sieve Tray [AMB TRAY 2]

A Sieve Tray is a variant of the cross-flow tray design, consisting of metal plates with perforations. Vapor ascends through these openings in the plate, while the liquid is held on the tray due to the flow of vapor. The configuration, quantity, and dimensions of the holes serve as key design parameters.

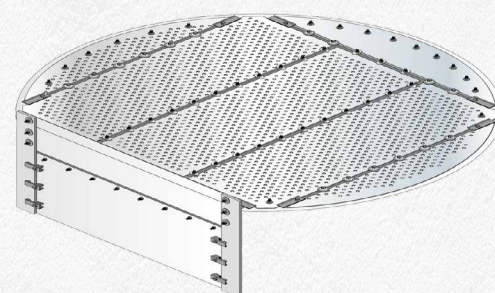

Material of Construction

SS 304/L, SS 316/L, 904L, 254SMO, Duplex, Super Duplex, Titanium, Hastelloy, Monel, Inconel, Copper or any metal/alloy as per customer request

Key Characteristics

Low cost. Not flexible for wide range of turndown ratio. High capacity and efficiency, low pressure drop, ease of cleaning, and low capital cost

Available Size

Sieve Trays are available up to 6m diameter



## Floating Valve Tray [AMB TRAY 3]

Float valves demonstrate high efficiency in handling varying flow rates. The inclusion of legs serves the purpose of ensuring continuous valve opening to prevent weeping and enhance mass transfer, particularly under low flow conditions. In specific situations, both light and heavy valves may be employed. The floating valve tray features an adjustable opening area that automatically adapts to vapor flow rates, providing a broad range of operational flexibility.

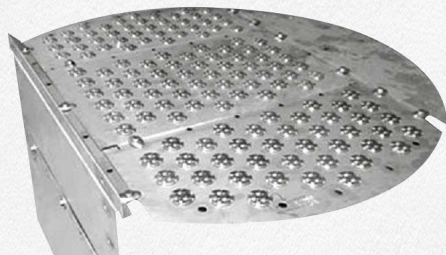

Material of Construction

SS 304/L, SS 316/L, 904L, 254SMO, Duplex, Super Duplex, Titanium, Hastelloy, Monel, Inconel, Copper or any metal/alloy as per customer request

Available Size

Floating Valve Trays available up to 6m diameter

## Fixed Valve Tray [AMB TRAY 4]

A valve is a non-moving part that is cut out from trays at a set distance. Fixed valve trays have a big advantage because the fast horizontal vapor speed through a narrow area mixes well with liquids flowing across and pushes any carried particles to the side before they go up. This helps with a quick transfer of substances. The high vapor speed also stops solids from settling or causing problems. Since it doesn't have parts that move, it works well with substances that can corrode.



Material of Construction

SS 304/L, SS 316/L, 904L, 254SMO, Duplex, Super Duplex, Titanium, Hastelloy, Monel, Inconel, Copper or any metal/alloy as per customer request

Key Characteristics

Fixed valve tray used for wider turndown ratio and better resistance to fouling compared to Sieve Tray.

Available Size

Fixed Valve Trays are available up to 6m diameter

## Structured Packing

For over 20 years, Ambani Metals has been a leader in crafting high-performance Structured Packing, specifically engineered to streamline substance transfer in thermal fractionation processes. Our extensive expertise and continuous refinement have culminated in a product renowned for its superior functionality and reliability.

Utilizing carefully selected thin metal sheets or mesh, our Structured Packing boasts a meticulously designed pattern, maximizing surface area and open spaces. This innovative configuration facilitates optimal mixing of gases and liquids, ensuring seamless substance transfer while maintaining uniform distribution and accommodating varying liquid levels. Trust Ambani Metals' Structured Packing to revolutionize your fractionation processes, delivering unparalleled efficiency and performance.



## AMBSTRUC Series Structured Packing [AMBSTRUC]

The AMBSTRUC structured packing is a useful and affordable product used in various industries today. It has good qualities like being able to predict how much substance it can handle, not causing too much pressure, working efficiently, and being flexible. This makes it important for separating different substances. The following sizes are available in X and Y type: AMBSTRUC 125 X, AMBSTRUC 125 Y, AMBSTRUC 210 X, AMBSTRUC 210 Y, AMBSTRUC 250 X, AMBSTRUC 250 Y, AMBSTRUC 350 X, AMBSTRUC 350 Y, AMBSTRUC 500 X, AMBSTRUC 500 Y, AMBSTRUC 750 X, AMBSTRUC 750 Y.



Material of Construction	Stainless Steel, Nickel Based Alloys, Hastelloy, Titanium, Tantalum, Monel
Application	Standard application, moderate vacuum to high pressure, low to high liquid loading
Available Size	F-factor : 1.2 to 3.5 Surface Area : 125 to 750 m <sup>2</sup> / m <sup>3</sup> NTSM: 1 to 4.4

## High Capacity Vantage Structured Packing [AMBSTRUC Plus]

Ambani's AMBSTRUC Plus Series structured packing is a special kind of material with a unique texture that helps liquids spread out really well. It controls how gases move and makes sure liquids don't get stuck in one place. This type of structured packing is often used in columns to make them hold more substance, reduce pressure, and can replace other materials like sheet metal, random packings, and trays.



Packing Types	AMB-HC 2.SL / AMB-HC 3.SL / AMB-HC 4 .SL / AMB-HC 6.2L / AMBHC 7.SL / AMB-HC 10.0L
Surface Area (m <sup>2</sup> /m <sup>3</sup> )	250 / 300 / 350 / 420 / 500 / 750
Application	Very low pressure drop and heat sensitive systems, high liquid & vapour loading
Material of Construction	Stainless Steel, Nickel Based Alloys, Hastelloy, Titanium, Tantalum, Monel
Key Characteristics	Available in both sheet metal and wire mesh, eliminates abrupt change in flow direction, eliminates premature build up of liquid, provides up to 50% higher capacity at the same NTSM compared to conventional structured packing, significantly lower pressure drop compared to conventional packing



## Wire Mesh Structured Packing [AMBESH]

Wire mesh packing has been used in industries for over 10 years and has proven effective for challenging separation tasks. It's typically used in smaller to medium-sized columns where a lot of theoretical stages are needed in a small column space.



Packing Types	AMB-WM 5.0M / AMB-WM 7.5L
Surface Area (m <sup>2</sup> /m <sup>3</sup> )	500 / 750
Application	High vacuum to low pressure drop requirement. Fatty alcohols, Processing of specialty chemicals, Monomers from plastics, Pharmaceuticals, Fine Chemicals, Isomer mixture separation.
Key Characteristics	Excellent wetting characteristics, Large number of theoretical stages, Low overall height, Capillary effect of special wire mesh, High fractionation efficiency and capacity, Large number of theoretical stages F-factor : 1.5 to 2.2 Surface Area : 500 to 750 m <sup>2</sup> /m <sup>3</sup> NTSM : 6 to 8.5

## Lab Structured Packing [AMB-LAB]

Ambani Metals also has special lab packing series AMB-LAB packing for research and development trials and pilot unit distillation. This packing is really good at its job with very little pressure drop (0.1 to 0.4 mbar per stage). It works well with small amounts of liquid (0.05 m<sup>3</sup> per square meter per hour), and it has a large surface area and NTSM.

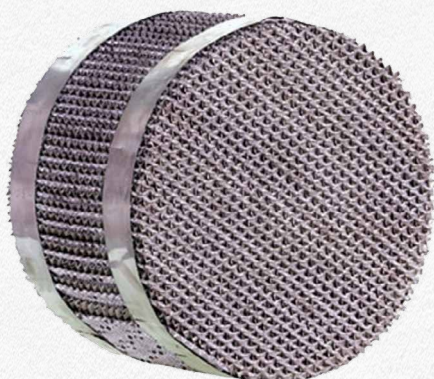

Series	AMBPAK - Lab 10, AMBPAK - Lab 20
Material of Construction	Stainless steel or any Metal/Alloy according to customer request
Application	Can be used for High vacuum to 2 mbar
Key Characteristics	NTSM : 20 - 40 Diameter : 25 - 100 mm



## Random Packing

Random packings are commonly used in gas, refinery, and chemical plants for absorption, stripping, and fractionation operations. They are a cost-effective way to increase a tower's capacity and efficiency.

Ambani Metals has a lot of experience and knowledge in this area, providing the best solutions for your critical applications. Using specially designed random packings from Ambani Metals can boost your tower's capacity without sacrificing efficiency. Their expert engineers can help you improve the performance of both new and existing towers, offering reliable solutions tailored to your needs.

Ambani Technology offers random packings in different sizes and materials like metal, plastic, or ceramic, depending on your specific requirements. They provide various packing sizes in common materials at competitive prices, ensuring quick delivery to minimize downtime for customers.

### AMB Pall Ring [AMB - PALL]

Pall rings were created by BASF AG in the 1940s, inspired by the Raschig ring. People still use them a lot in different industries because they can hold a good amount of stuff without needing much pressure. Metal Pall Rings come in different types like Stainless Steel, Carbon Steel, Aluminium, and Copper.

#### METAL PALL RING

Size	10 to 75 mm
Bulk Density	140 - 520 kg/m <sup>3</sup>
Surface Area	120 - 500 m <sup>2</sup> /m <sup>3</sup>
NTSM	1.8 to 2.2
Thickness	0.3 to 0.6 mm

#### PLASTIC PALL RING

Size	16 to 90 mm
Bulk Density	43 - 95 kg/m <sup>3</sup>
Surface Area	985 - 340 m <sup>2</sup> /m <sup>3</sup>
NTSM	1.8 to 2.5
MOC	PP, PVDF, PTFE & PFA

#### CERAMIC PALL RING

Size	25 to 50 mm
Bulk Density	535 - 640 kg/m <sup>3</sup>
Surface Area	120 - 220 m <sup>2</sup> /m <sup>3</sup>
NTSM	1.4 to 1.8





## AMBRR Raschig Ring [AMB - RR]

We also offer specially designed Lab packing for R&D trails and pilot unit distillation. These are very efficient packing with very low pressure drop 0.1 to 0.4 mbar/stage, suits low liquid load 0.05 m<sup>3</sup>/m<sup>2</sup>h, higher surface area and NTSM.

### METAL RASCHIG RING

Size	10 to 80 mm
Bulk Density	130 - 540 kg/m <sup>3</sup>
Surface Area	71 - 430 m <sup>2</sup> /m <sup>3</sup>
NTSM	1.5 to 2
Thickness	0.3 to 1 mm

### PLASTIC RASCHIG RING

Size	25 to 50 mm
Bulk Density	86 - 92 kg/m <sup>3</sup>
Surface Area	95 - 205 m <sup>2</sup> /m <sup>3</sup>
NTSM	2.0 to 2.5
MOC	PP, PVDF, PTFE & PFA

### CERAMIC RASCHIG RING

Size	15 to 75 mm
Bulk Density	500 - 710 kg/m <sup>3</sup>
Surface Area	70 - 330 m <sup>2</sup> /m <sup>3</sup>
NTSM	1.4 to 1.7



## AMBSR Saddle Ring [AMB - SR]

Metal Saddle Rings are a type of random tower packing suitable for high-capacity and highperformance applications.

### METAL SADDLE RING

Size	15 to 70 mm
Bulk Density	90 - 350 kg/m <sup>3</sup>
Surface Area	60 - 285 m <sup>2</sup> /m <sup>3</sup>
NTSM	2.2 to 2.5
Thickness	0.3 to 0.6 mm







## PLASTIC SADDLE RING

Plastic Saddle Ring is sometimes called a super saddle ring or plastic super Intalox saddle. It looks like a saddle and is an improved version of another plastic Intalox saddle. The difference is that it has a wavy edge instead of a smooth one. This change makes more spaces between the packing and helps the gas and liquid spread out better in the layers.

Size	25 to 75 mm
Bulk Density	48 - 83 kg/m <sup>3</sup>
Surface Area	89 - 210 m <sup>2</sup> /m <sup>3</sup>
NTSM	2 to 2.5
MOC	PP, PVDF, PTFE & PFA



## CERAMIC SADDLE RING

Ceramic saddles are often used as random packings, especially when dealing with corrosive substances. They have a smooth surface that makes them resistant to chemicals and stable. Saddles are a cost-effective choice and are commonly used in places like acid gas scrubbers, dryer towers, and tail gas scrubbers.

Size	13 to 75 mm
Bulk Density	545 - 725 kg/m <sup>3</sup>
Surface Area	91 - 625 m <sup>2</sup> /m <sup>3</sup>
NTSM	1.8 to 2.6

## Cascade Mini Ring [AMB - CMR]

The Cascade Mini Ring is a type of random packing crafted from materials like carbon steel or stainless steel. It typically looks like a cylinder with multiple open windows on the surface and an expanded, trumpet-shaped opening at one end. This random packing is known for its improved efficiency in mass transfer and better separation results compared to Metal Intalox Saddle and Metal Raschig Ring.

## CASCADE MINI RING

Size	10 to 50 mm
Bulk Density	150 - 270 kg/m <sup>3</sup>
Surface Area	50 - 250 m <sup>2</sup> /m <sup>3</sup>
NTSM	2.2 to 2.5
Thickness	0.3 to 0.6 mm





## Column Internals

Ambani Metals has a special team focused on improving the movement of substances in columns. They create, produce, and provide materials for columns that are crucial for important uses. In a column system, the materials inside can work best when they are used with the right distributors, collectors, supports, and other parts to make sure liquids and gases spread out properly.

We make these materials using high-quality raw materials and advanced techniques. Our offered materials are known for excellent performance, needing little maintenance, being strong, precise in size, and having a small design. We've created a variety of these materials that are used in industries like oil processing, chemicals, desalination, petrochemicals, and gas-liquid absorption units.

## Liquid Distributor & Redistributors [AMB - D/AMB - RD]

Packings, whether they are random or structured, are used to make sure liquids and gases can mix well in processes where substances move between them. However, for these packings to work really well, they need some extra parts, known as internals. Ambani specializes in creating, producing, and providing these efficient and cost-effective internals to its customers.

## Chimney Tray Collector - Distributor [AMB - CCR]



Chimney Collector trays are used to gather liquid from packed beds during tray transition. They are needed in various situations, like drawing off liquid either partially or completely. There are different types of these trays to fit the amounts of vapor and liquid.

**Key Characteristics:** Chimney tray distributors work well with a lot of liquid and larger columns. They can act as both distributors and redistributors, helping with collecting and spreading liquid. The design of the chimney is crucial and depends on how the liquid and vapor flow, as well as pressure drop requirements.

In some cases, these trays can be provided without holes for a partial or 100% draw of liquid.

## Feed Pipe Distributor [AMB - FPD]

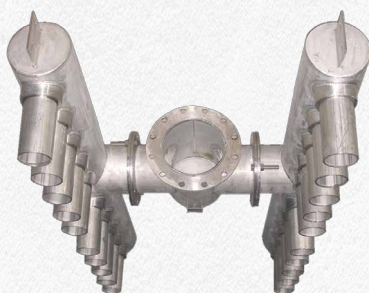

The Pipe Type Distributor is a straightforward design that can be highly effective when there is a high vapor flow. Its simple construction with pipes allows for a large volume for the vapor to flow through.

**Key Characteristics :** Pipe Type Distributors can manage liquid loads ranging from 20 to 25 m<sup>3</sup>/m<sup>2</sup>h. They are suitable for sizes starting from 500mm and above. Although they can be designed for smaller sizes, the installation process becomes more challenging. Manufacturing can be accomplished as a single piece, or the arms can be of the flanged type to easily pass through manways.



## L- L Extraction Distributor [AMB - ED]

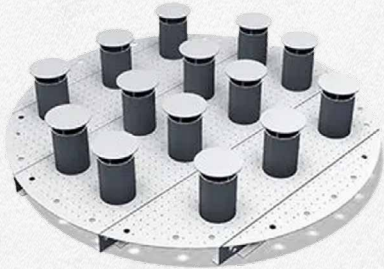

These are employed in packed liquid-liquid extraction columns for both continuous and dispersed phases, helping to avoid emulsions, especially at low surface tensions.

## Spray Nozzle Type Distributor [AMB - SND]



A spray nozzle distributor is a common type of liquid distributor in packing towers. It has a compact design and works by spraying liquid onto the tower packing through nozzles when pressure is applied. This distributor is increasingly used for processes involving heat exchange and scouring.

**Key Characteristics :** The spray nozzle type distributor uses cone spray nozzles instead of distribution holes to evenly spread liquid. An advantage of this type is that liquids with solid particles can be distributed without causing problems like clogging the nozzles. The spray nozzle distributor is made up of a main header, laterals with downpipes, and spray nozzles.

**Distributor Liquid Loading :** 2 to 200 m<sup>3</sup>/m<sup>2</sup>h

**Distributor Size :** upto 6m

## Through Type Distributor [AMB - TTD]

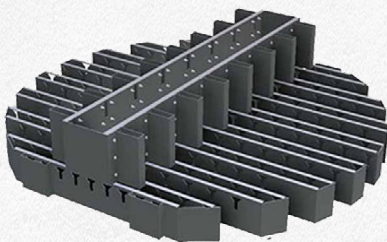

The liquid distributor LO features troughs with lateral notches serving as discharge openings. These troughs are supplied by a parting box, making this distributor highly resistant to fouling and broadening its range of applications. A trough type distributor includes a pre-distribution opening, also known as a 'parting-box,' positioned above several evenly spaced narrow troughs.

**Key Characteristics :** The through-type distributor construction is suitable for handling very high liquid loads and larger column diameters, typically starting from 900 mm and above. This type of distributor allows for both bottom holes and tube construction. In the top-through distributor, liquid flows through bottom channels, ensuring an even distribution across the surface of the packing.

Can be used for both structured & random packing. Liquid loads may vary from 2 m<sup>3</sup>/m<sup>2</sup>hr to 50 m<sup>3</sup>/m<sup>2</sup>hr.

The simplicity of this design helps to get good seating, better leveling and easiness of installation.



## Vane Type Collectors [AMB - VC]



Also known as "Ring Type Collectors", these collectors have very low-pressure drop.

**Key Characteristics:** It requires a ring channel which is then welded to the column wall. The pressure drops are low, lesser losses.

## Flanged Type Collectors [AMB - FC]

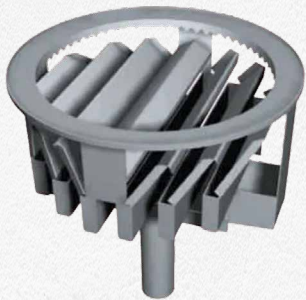

This is suitable for comparatively smaller diameter columns where manholes are not practical and the column sections are flanged in construction.

**Key Characteristics:** These Collectors are normally used in small diameter column. These are designed to be installed between column flanges.

## Chimney Tray Type Collectors [AMB - CC]



Normally used for large diameter columns with high liquid throughput, it is available in both welded and bolted structures.

**Key Characteristics :** Liquid collection from above bed and conduction to below distributor. Has a lateral downcomer shaft. Total or partial liquid draw-off is possible.

## Collectors With Support Grid [AMB - SGC]



This is a combination of packing support grid and vane type collector.

**Key Characteristics :** These Collectors consists of inclined and overlapping lamellas. These are designed to be installed between column flanges

## Demister Pads [AMB - DEM]

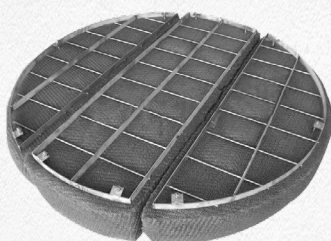

Demister pads are made using high-quality raw materials and advanced technology, resulting in efficient operation with reduced time and power consumption. These products are created in accordance with current industry trends and standards.



# RELIABLE FOUNDATION, REMARKABLE FUTURES.

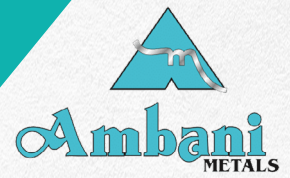

Our products find extensive applications in various industries such as Petroleum, Chemicals, Metallurgy, Pharmaceuticals, and Automobile. Known for their superior functionality, high quality, and user-friendly features, our products come in various sizes and models tailored to meet clients' specific requirements.

Mesh demisters can be installed either horizontally or vertically. When gas flows horizontally through the demister, it has a 30% greater capacity compared to vertical flow, allowing for a smaller demister size.



**Website**

<http://www.ambanimetal.com>



**Head Office**

Office no. 2, 2<sup>nd</sup> floor, Nebula Tower, Sindhi Lane, Mumbai - 40004, Maharashtra, India.



**Email**

[sales@ambanimetal.com](mailto:sales@ambanimetal.com)  
[export@ambanimetal.com](mailto:export@ambanimetal.com)



**Contact Person**

Jay Shah - Domestic Division - +91 83692000178  
Manan Bokadia - Export Division - +91 9930498865